

## **VACUUM CLAMPS**

### **MODEL VTC**

- Strong Vacuum Connection
- Quick Attachment
- Easy to use
- Ideal for flat or curved surfaces

On request can be supplied with ATEX certification  
To ATEX 95 94/9/EC  II 2 G & D Zone 1, 2 & 21, 22

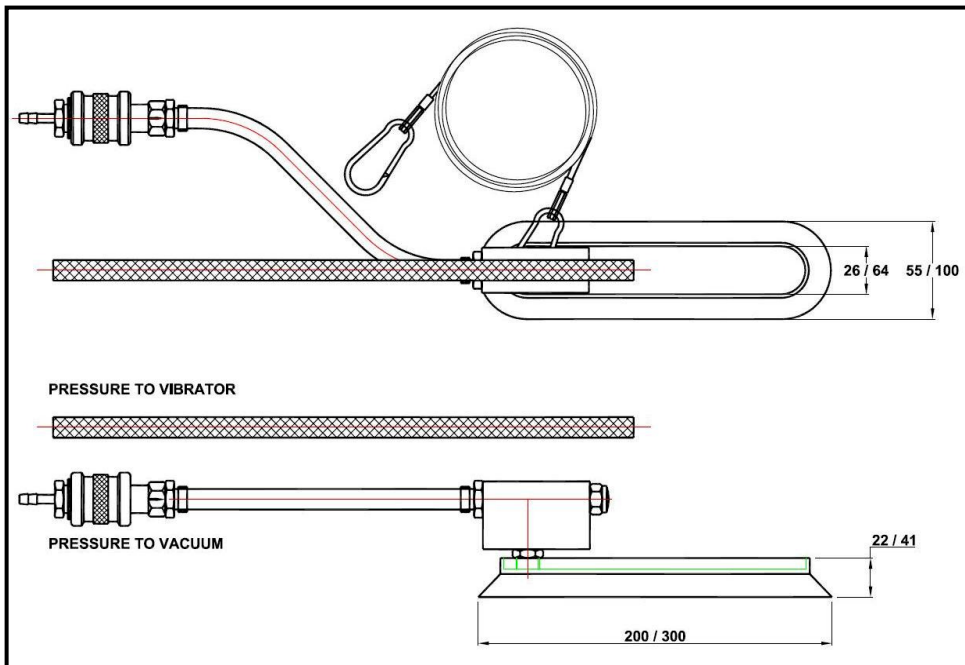

**VTC 15/20S**

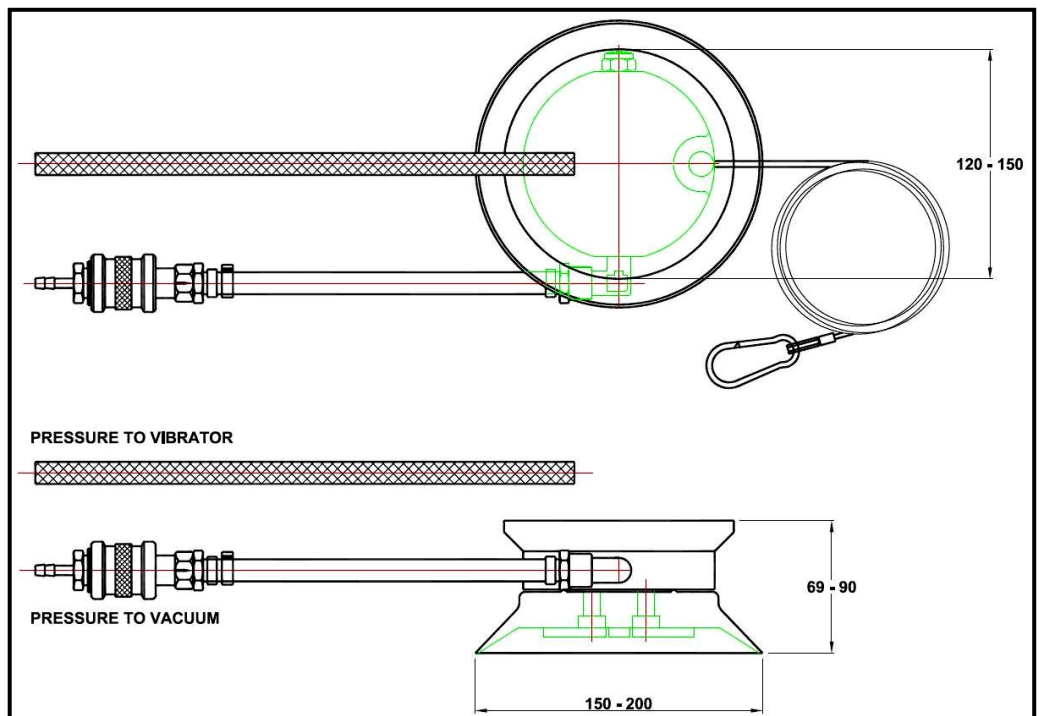

**VTC 15/20D**

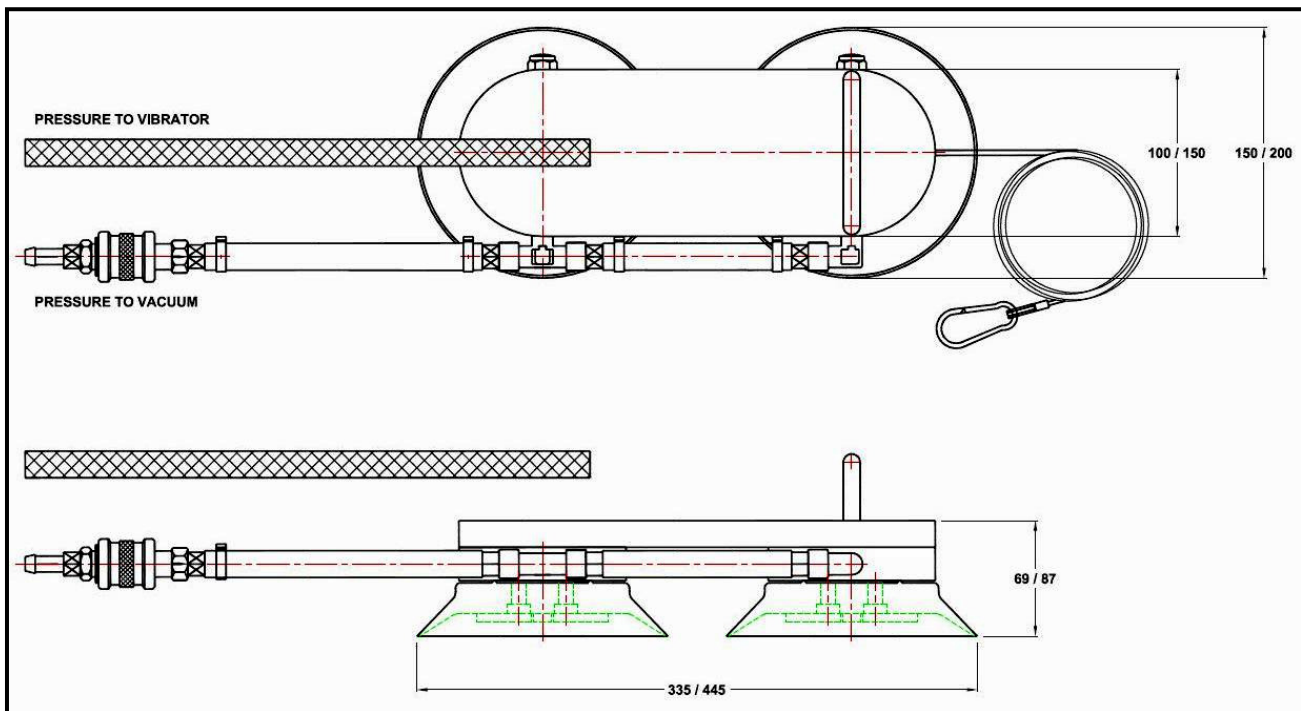

## VTC 20T

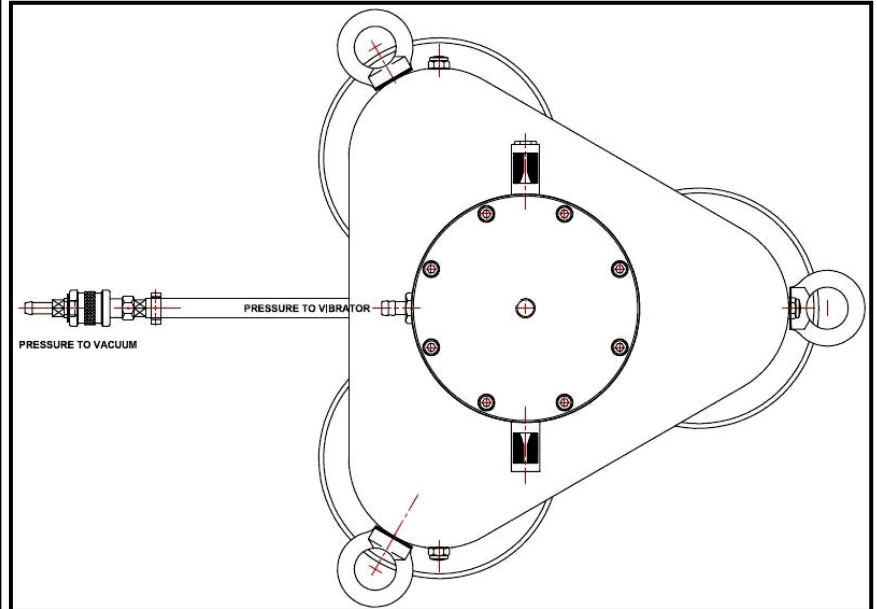
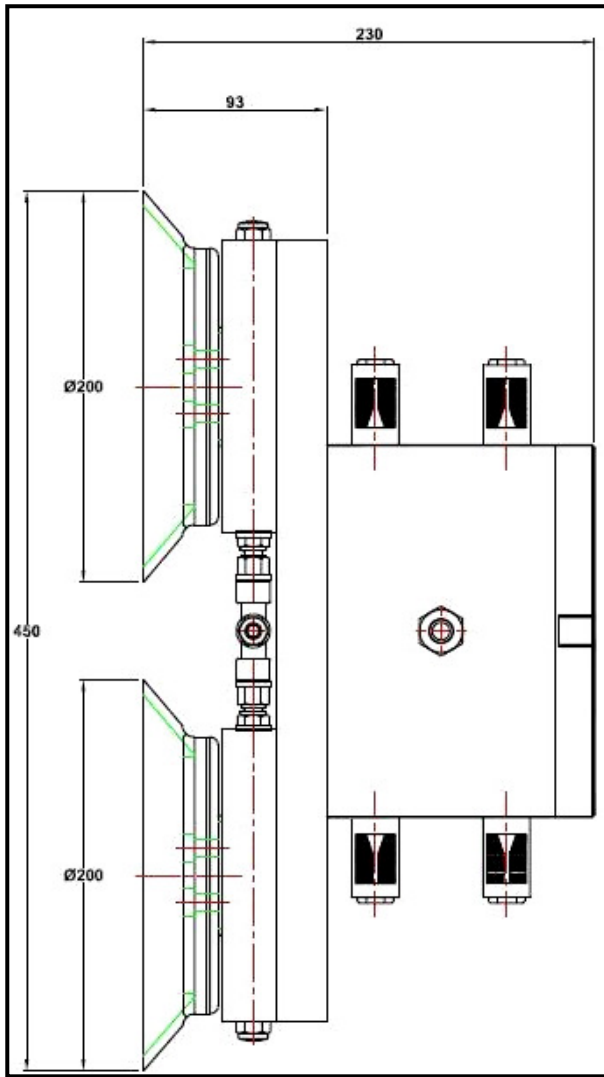

### COMPATIBILITY

MODEL	COMPATIBLE UNITS	Min Diameter mm	Air Consump. CFM (litr)	Weight (Kgs)
VTC 10S	DAR2, K8-10, GT4-10, FP12-18, R50, T50, VTL155-165, FAL 18	110	2.79 (79)	1.5
VTC 12S	DAR2 / DAR4, K8-25, FP25-35, R50-80, GT08-25, T50-80, V150	350	2.79 (79)	3.0
VTC 15S	DAR2-3, K8-16, GT4-16, FP12-18, R50-65, T50-65, VTL155-255, FAL18-25	760	2.79 (79)	2.5
VTC 15D	DAR4, GT20-30, K20-36, R80, T80, FP25-FP35, FAL25-35, FP50M, VFP75/01, VFP50/01	760	5.58 (158)	4.5
VTC 20S	K20-25, GT20-25, FP50M-60M, FAL35, R80, T80, VFP54/02	860	2.79 (79)	4.0
VTC 20D	DAR5, GT30-36, R100, T100HP, FP60M, FP95M	860	5.58 (158)	8.5
VTC 20T	VFP50/10	4600	8.37 (237)	18.0