



---

**PNEUMATIC IMPACTING VIBRATORS**

---

**MODEL V150 - V170 - V200**

- Linear Impactor
- High Force
- Robust Construction
- Suitable for temperature up to 80 °C

On request can be supplied with ATEX certification  
To ATEX 95 94/9/EC  II 2 G & D Zone 1, 2 & 21, 22

## PERFORMANCE DATA

MODEL	Impacts per Minute @ 5.5 Bar	Air Consumption @ 5.5 Bar	Hopper Wall mm	Weight kgs
V150S	Single Impact	0.8 litres per impact	2 - 4	3.30
V150C	Continuous Impacts - variable from 6-100/min	0.8 litres per impact	2 - 4	3.80
V170S	Single Impact	1.7 litres per impact	3 - 5	11.0
V170C	Continuous Impacts - variable from 6-100/min	1.7 litres per impact	3 - 5	11.5
V200S	Single Impact	3.6 litres per impact	4 - 8	22.0
V200C	Continuous Impacts - variable from 6-100/min	3.6 litres per impact	4 - 8	22.5

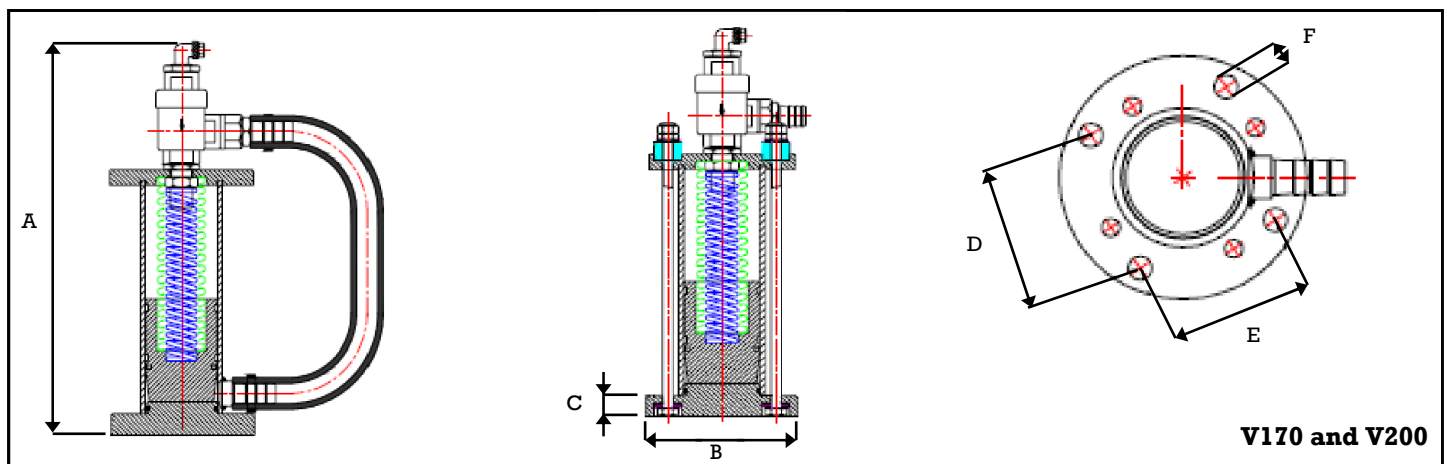
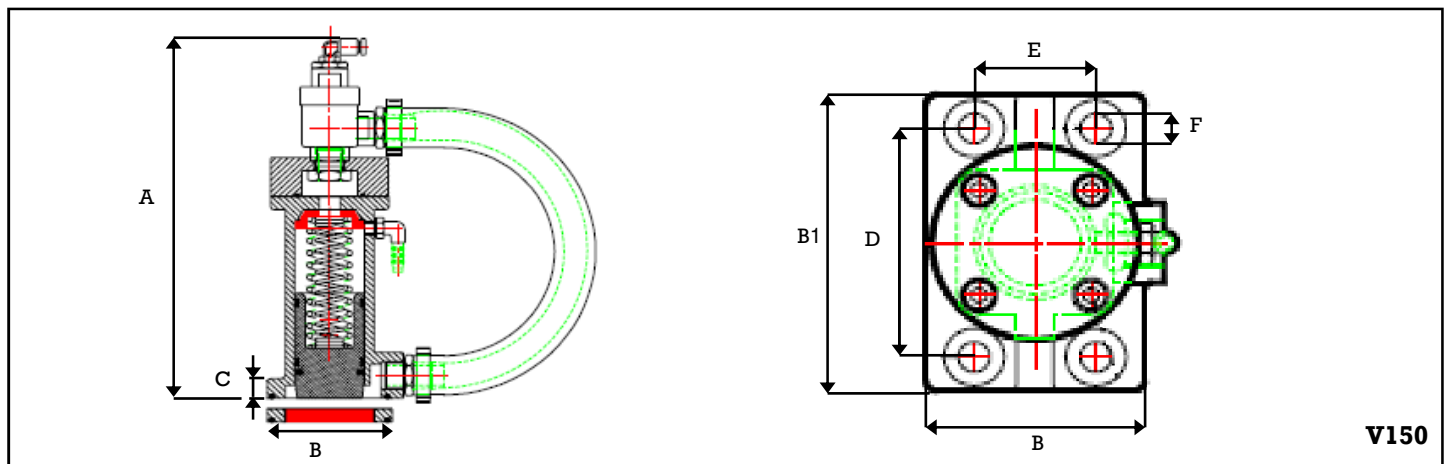

## DIMENSIONS

MODEL	A mm	B x B1 mm	C mm	D mm	E mm	F mm
<b>V150</b>	278	90 x 130	15	100	50	Ø13
<b>V170</b>	381	Ø140	20	81.5	81.5	Ø13.5
<b>V200</b>	412.5	Ø180	24	107.5	107.5	Ø17