

---

## **PNEUMATIC BALL VIBRATORS**

---

### **MODEL SK**

- **Small and Lightweight**
- **Assists the flow of materials from chutes and hoppers.**
- **Plastic construction**
- **Compaction of materials in containers or moulds**
- **Force adjustable by air pressure**
- **Force 403 N to 4464 N**

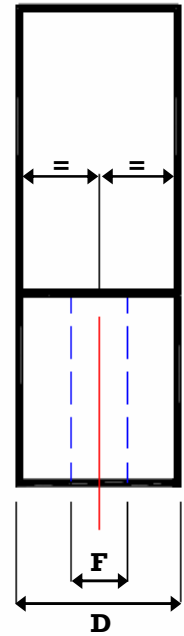
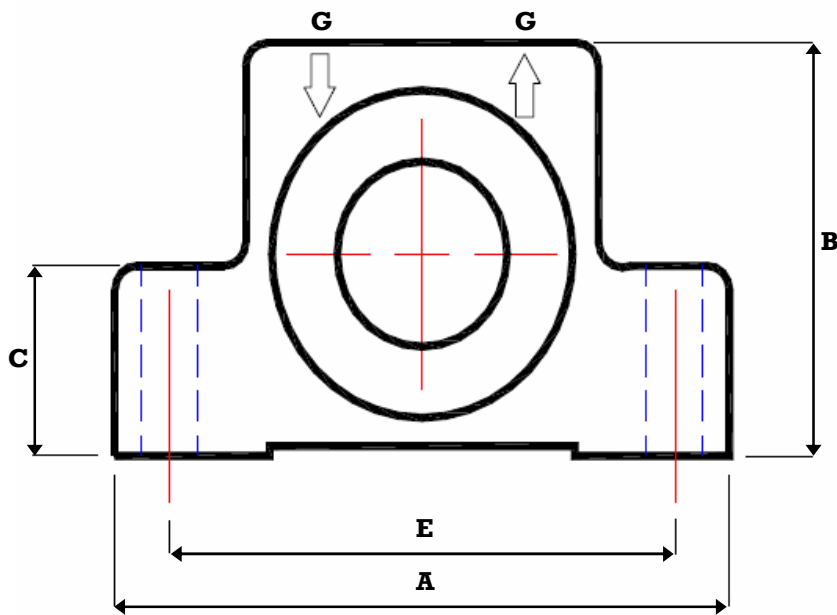

## PERFORMANCE DATA

MODEL	RPM (80 PSI / 5.5 bar)	Force (kgs)	Air Consumption (l/min)	Weight (kgs)
SK10	24000	403	240	0.3
SK13	20000	481	300	0.5
SK16	15000	775	470	0.6
SK19	14000	1050	490	1.0
SK25	9000	1207	550	1.1
SK35	8500	2070	570	1.1
SK38	6000	3022	830	2.2
SK41	5800	3414	830	2.7
SK44	5600	3758	910	2.7
SK51	5300	4464	910	2.9

## DIMENSIONS

MODEL	A (mm)	B (mm)	C (mm)	D (mm)	E (mm)	F Diam. (mm)	G BSP
SK10	126	68	34	30	101	10	1/8"
SK13	126	68	34	30	101	10	1/8"
SK16	141	87	40	37	116	10	1/4"
SK19	141	87	40	37	116	10	1/4"
SK25	163	101	51	50	132	12.5	1/4"
SK35	163	101	50	50	132	12.5	1/4"
SK38	228	149	74	63.5	190	17	1/2"
SK41	228	149	74	63.5	190	17	1/2"
SK44	228	149	74	63.5	190	17	1/2"
SK51	228	149	74	63.5	190	17	1/2"